



# Reelable cables

---

Handling and installation instructions

Drumable cables are designed for demanding applications that require flexible and reliable power and signal transmission. These instructions contain the most important installation information to ensure a long service life and smooth operation.

### Observe temperature limits

- Installation should not be carried out at temperatures below +5°C.

### Transport

- Transport the delivery drum to the place of use with a cable transport trolley or truck.
- Avoid unnecessary rolling of the cable drum; always observe the specified rolling direction.

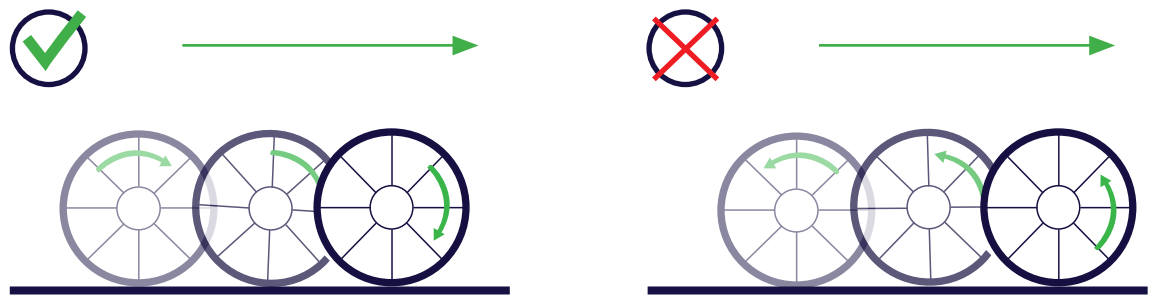

### Torque freedom

- To prevent damage to the cable, it must always be rolled up and unrolled without twisting. It must also be connected and secured without twisting at the supply point.

### Bonding/looping

- Must be absolutely avoided when drumming and during installation!

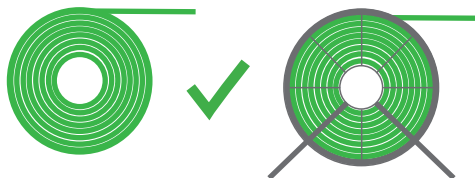

### No sharp edges

- When installing, ensure that the cable is not pulled over edges or kinked.

- Place the drum in close proximity to the system
- Lay out the entire length of cable before installation using cable laying rollers

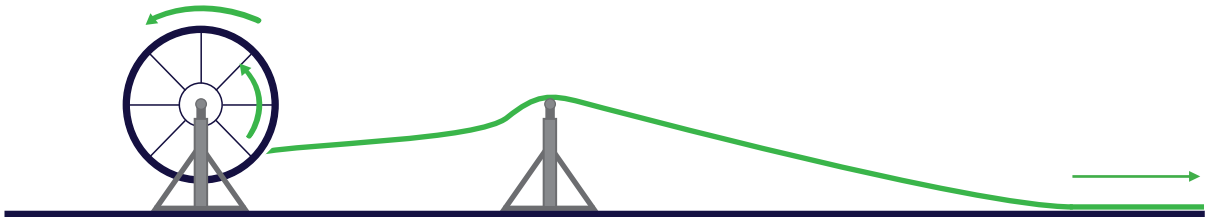

- Ideally, avoid rewinding directly from the delivery reel to the device reel.
- If the cable cannot be laid out straight due to space constraints, the distance between the delivery reel and the device reel should be kept as large as possible
- Use a pull rope and pull sock for unwinding
- 24 hours before installation, lay out the length to be laid in order to allow time for conditioning/relaxation

### 3.1 Unwinding the cable

- The cable may only be pulled from the transport drum from above.
- The stranding direction specified by the manufacturer must be observed.

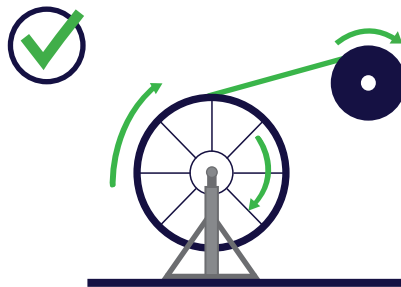

2.1 Correct

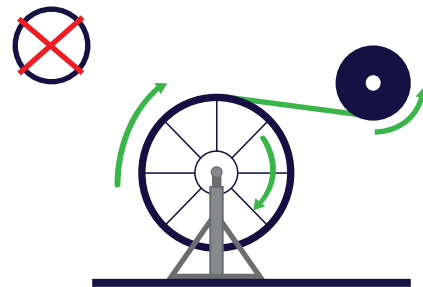

2.2 Wrong

Unwinding against the stranding direction (2.2), i.e., against the winding direction, can cause the wires to attempt to reverse themselves in their stranded composite, thereby affecting the proper functioning of the cable, which can even lead to a subsequent malfunction/failure of the cable.

- S-shaped deflection or deflection into another plane is not permitted
- Unwinding with a deflection of, for example, 90 degrees is not permitted

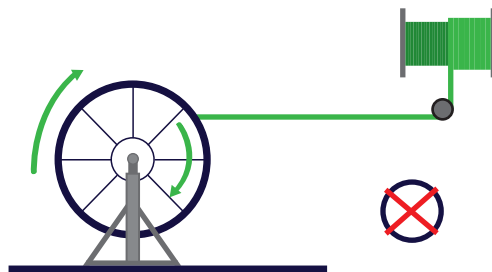

- Deflection rollers must not have a concave shape and must be at least 10% larger than the cable diameter.

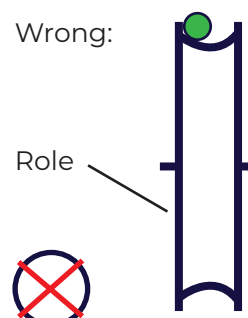
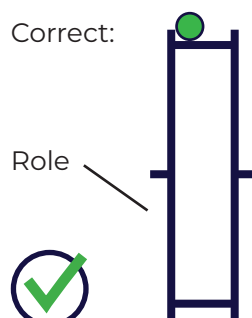

### 3.2 Winding onto the drum

Depending on the position of the cable entry on the drum body, it is strongly recommended to observe the correct unwinding direction of the first layer on the device drum as shown in the illustration. Otherwise, damage to the wire assembly may occur.

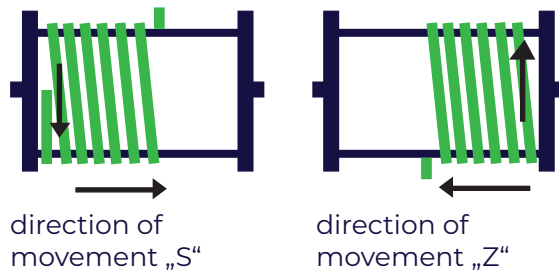

- The cable must be wound onto the device drum without twisting.
- For cables with a “Z” stranding direction (right-handed), the winding direction must be clockwise.
- For cables with an “S” stranding direction (left-handed), the winding direction must be counterclockwise.
- Failure to comply with this requirement may result in irreparable damage to the cable or the devices

### 3.3 Use of pre-assembled cables

For pre-assembled cables, first connect the end termination to the device drum (slip ring body) without twisting, clamp the cable, wind it onto the device drum, and then connect and secure it to the feed without twisting.

- Do not drag end terminations across the floor
- If cables are supplied without end terminations, these must be installed after laying.

### 3.4 Minimum bending radii

Compliance with the minimum bending radii has a particularly positive effect on the service life of the cable. The table below lists the most important applications. The minimum bending radius is calculated based on the maximum outer diameter of the cable. Ambient temperatures and tensile loads must be taken into account.

#### Smallest permissible minimum bending radii $R_{\min}$

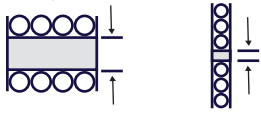
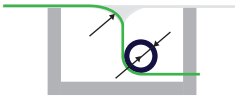
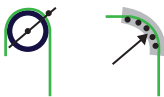
Cable types	Reelable low-voltage cables				Reelable high-voltage cables	Fiber optic cable minimum permissible bending radius
	> 0,6 kV/1 kV				< 0,6 kV/1 kV	
Nominal voltage $V_0 / V$						
Maximum outer diameter of the cable or maximum thickness of flat cable (mm)	<8	8 - 12	12 - 20	>20		
For forced guidance such as drum operation 	5 x $\emptyset$	5 x $\emptyset$	5 x $\emptyset$	6 x $\emptyset$	12 x $\emptyset$	250 mm
When introducing, e.g., into a center supply 	3 x $\emptyset$	4 x $\emptyset$	5 x $\emptyset$	5 x $\emptyset$	12 x $\emptyset$	250 mm
In the case of forced guidance such as roller deflection 	7,5 x $\emptyset$	7,5 x $\emptyset$	7,5 x $\emptyset$	7,5 x $\emptyset$	15 x $\emptyset$	250 mm

#### Minimum distance $A_{\min}$ between deflections

With double or S-shaped deflection 	20 x $\emptyset$	20 x $\emptyset$	20 x $\emptyset$	20 x $\emptyset$	20 x $\emptyset$	50 x $\emptyset$
---------------------------------------------------------------------------------------------------------------------------	------------------	------------------	------------------	------------------	------------------	------------------

- Never use a reeling cable without adequate strain relief.
- The use of cable retention socks or large-area clamps is recommended.
- Place at least 2 full turns on the reel.
- Use cable pulling socks with single or double eyelets.

During reeling, the cores inside the cable must be able to move slightly in order to ensure length compensation around the neutral fiber.

Correctly installed strain relief significantly extends the service life of the cable. Strain relief drums (underground or above ground) are ideally used for both center and end feeders. It is particularly important to ensure that the strain relief drum complies with the minimum bending radius  $R_{\min}$  for the cable and that the settling distances  $A_{\min}$  are observed.

Optimal, secure installation of the strain relief is only possible if at least 2 full turns are made on both the reel of the motorized cable reel and the strain relief reel!

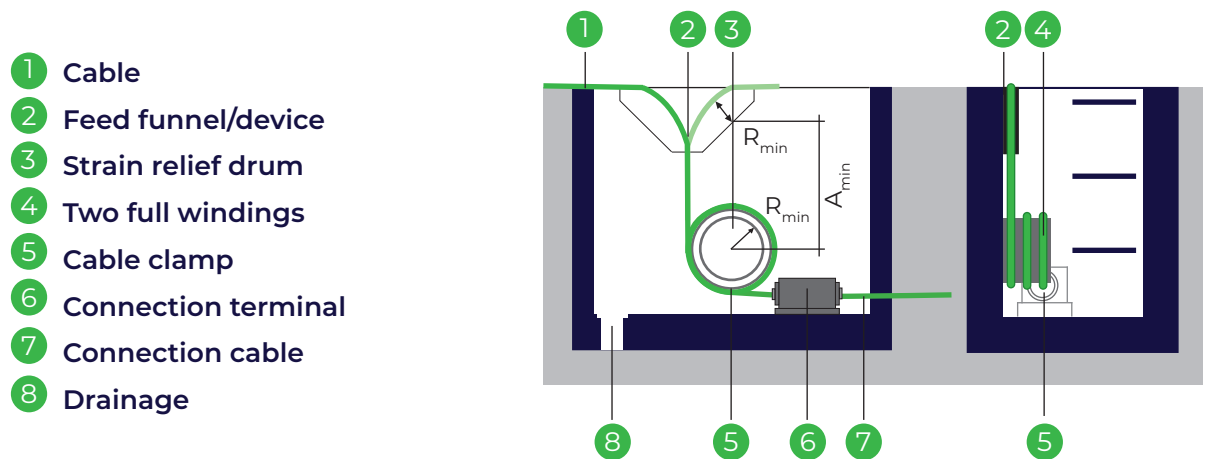

Another option for strain relief is to use cable pulling socks, which prevent punctual stress on the cores in their stranded connection.

The correct cable pulling sock is determined based on the cable diameter. A cable pulling sock with one eyelet is the standard version.

For vertical applications with higher tensile forces, or for center feeding, the use of cable pulling socks with 2 eyelets is recommended, as these absorb the forces better due to their symmetrical arrangement.

For impacts or extreme tensile forces (e.g., spreader applications), systems with strain relief springs or rubber rope packages are used.

### 5.1 Is the feed-in...

... underground in the center of the roadway, one or two cable turns must be laid around a strain relief drum after the entry funnel. The cable is then clamped and connected.

... above ground at the end of the track, when the device is in its end position, the section of cable that is no longer drummed should be at least 40 times the cable diameter before the fastening clamp at the feed-in point, or the cable should be guided over a compensating disc with one or two turns, then clamped and connected.

### 5.2 Center feed, installation

In order to extend the travel distance of large electrical systems, such as harbor cranes, the device is often powered via the center of the travel path. With this type of power supply, each time the center is crossed, the direction of the cable changes. In order not to impair the service life of the cable, it is essential to follow the installation instructions.

- 1. Attaching the cable to the strain relief drum:** We recommend wrapping the cable around the strain relief drum  $2\frac{1}{2}$  times to absorb the tensile forces that occur during operation. The corresponding bending radii must be taken into account.
- 2. Securing the cable in the center feed:** The basic purpose of the strain relief drum is to absorb the tensile forces that occur over as long a cable length as possible in order to prevent cable damage or failures due to a clamping point. After  $2\frac{1}{2}$  turns of the cable on the strain relief drum, it can be assumed that the cable is free to move and can be guided using a clamp. (see Figure 1)

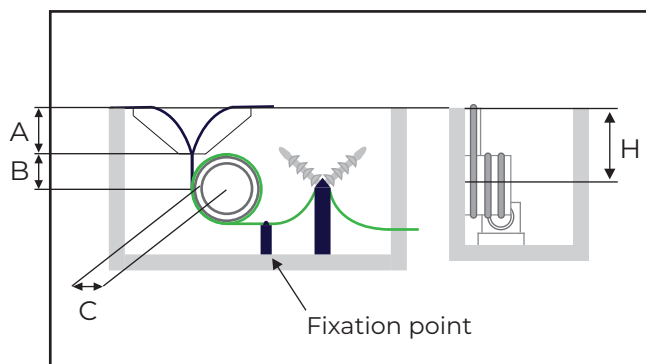

Figure 1

#### $H > A+B$

Travel speed m/min	A	B	C
< 100	$12 \times D$	$6 \times D$	$6 \times D$
> 100 und < 200	$12 \times D$	$12 \times D$	$12 \times D$

A = Radius introduction funnel

B = Rest zone

C = Radius of strain relief drum

D = Cable diameter

H = Height of strain relief drum

### 3.3 Use of pre-assembled cables

- Perform a visual inspection after installation and laying.
- Check for damage, twisting, kinks, or incorrect bending radii.
- Test the voltage before commissioning.
- Check the installation after approx. 24 hours of operation and, after trial operation, readjust the parameters as necessary.

These instructions are based on current standards, manufacturer recommendations, decades of practical experience, and proven use in the field. Professional installation by qualified personnel is essential to ensure the highest safety and quality standards.

In addition to the above guidelines, please also observe the applicable electrical installation guidelines for cables and wires, as described by the VDE, among others.



**TKDE**  
an INFINITE® brand

About Infinite Electronics

Infinite Electronics has a global portfolio of leading in-stock connectivity solution brands. Infinite's brands help propel the world's innovators forward by working urgently to provide products, solutions, and real-time support for their customers.

Backed by Warburg Pincus, Infinite's brands serve customers across a wide range of industries with a broad inventory selection, same-day shipping and 24/7 customer service. Learn more at [infiniteelectronics.com](http://infiniteelectronics.com).

**TKD Kabel GmbH**

**An der Kleinbahn 16**

**41334 Nettetal**

**Phone +49 (0) 2157 8979-0**

**E-Mail [info@tkd-kabel.de](mailto:info@tkd-kabel.de)**

**[www.tkd-kabel.de](http://www.tkd-kabel.de)**